

TE24200

25.6V 200Ah

Smart Lithium iron phosphate battery



Littech 25.6V 200Ah SMART LITHIUM IRON PHOSPHATE BATTERY

Littech intelligent lithium iron phosphate battery is equipped with automatic balancing function, providing more flexible usage scenarios. The integrated intelligent battery management system (BMS) can not only protect the battery from various abnormal influences, supervise and manage the charging/discharging process. Built-in high and low temperature protection, ABS reinforced bracket, anti-vibration design, particularly suitable for harsh road conditions and complex usage scenarios, weighing 36kg, with a long cycle service life.

KEY FEATURES

Auto-Balance

Cell balance design inside the Smart BMS, optional active balance.

Ultra-Safety

The Battery management system(BMS) provides comprehensive protection to the battery and manages the charging/discharging process wisely.

2S2NP Directly Strings up

The battery management system (BMS) supports up to 2 series connections, with no limit on the number of parallel connections (number of series connections *n)

Resist Vibration Design

ABS Reinforce Holder, resist vibration design, especially design for those bad road condition.

Lighter and Smaller

520*269*220mm dimension, 36kg only, easy for lead-acid replacement, maintenance free.

ELECTRICAL SPECIFICATIONS

Nominal Voltage	25.6V
Nominal Capacity	200Ah
Capacity @20A	600min
Energy	5120Wh
Resistance	≤30mΩ @ 50% SOC
Efficiency	99%
Self Discharge	≤3.5% Per Month
Maximum Modules in Series or Parallel	2S2NP

MECHANICAL SPECIFICATIONS

Dimensions[L*W*H]	520*269*220mm
Weight	36KG
Terminal Type	M8/M6
Case Material	ABS
Enclosure Protection	IP55
Cell Type	Prismatic
Chemistry	LiFePo4
Configuration	8S2P

DISCHARGE SPECIFICATIONS

Maximum Continuous Discharge Current	100A
Peak Discharge Current	130±10A≤10s
BMS Discharge Current Cut-off	300±50A[500~400ms]
Recommend Low Voltage Disconnect	22.4V
BMS Discharge Voltage Cut-off	20V[2.5±0.1V][2±1s]
Reconnect Voltage	25.6V[2.7±0.1V]
Short Circuit Protection	70-1500μs

CHARGE SPECIFICATIONS

Remomend Charge Current	20A-100A
Maximum Charge Current	100A
Recommend Charge Voltage	28.4-29.2V
BMS Charge Voltage Cut-off	29.2V[3.65±0.1V] [2±1s]
Reconnect Voltage	27.6V[3.45±0.1V]
Balancing Voltage	26.4V[3.3±0.03V]
Balancing Current	20-70mA

TEMPERATURE SPECIFICATIONS

Discharge Temperature	-4 to 140°F[-20 to 60°C]
Charge Temperature	32 to 131°F[0 to 55°C]
Storage Temperature	23 to 95°F[-5 to 35°C]
High Temperature Cut-off Discharge	140F[60°C][Customized]
Low Temperature Cut-off Disharge	-4°F [-20°C][Customized]
Reconnect Temperature	122F[50°C][Customized]
Low Temperature Cut-off Charge	32°F[0°C][Customized]
High Temperature Cut-off Charge	131°F[55°C][Customized]

COMPLIANCE SPECIFICATIONS

Certifications	CE[Battery] UN38.3[Battery] IEC62133[cell]
Shipping Classification	UN3480, CLASs9

DIMENSIONAL SPECIFICATIONS

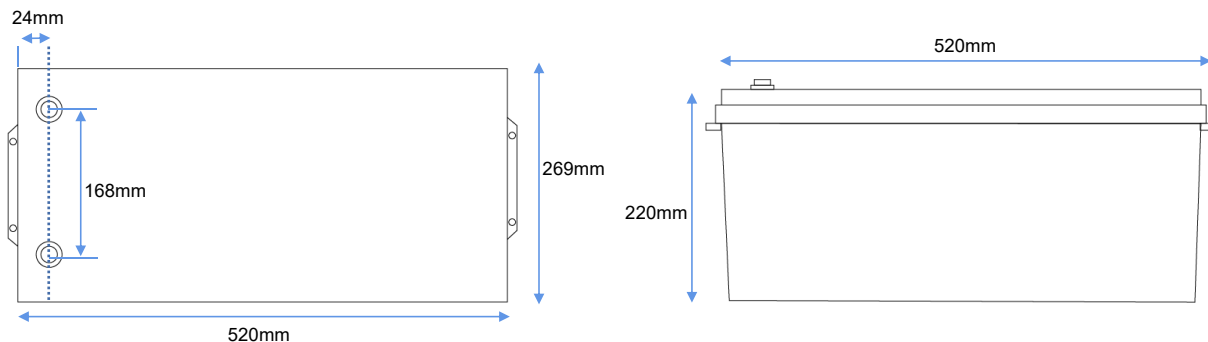

Charge/Discharge Capacity At Different Rates for cell [Room Temperatue]

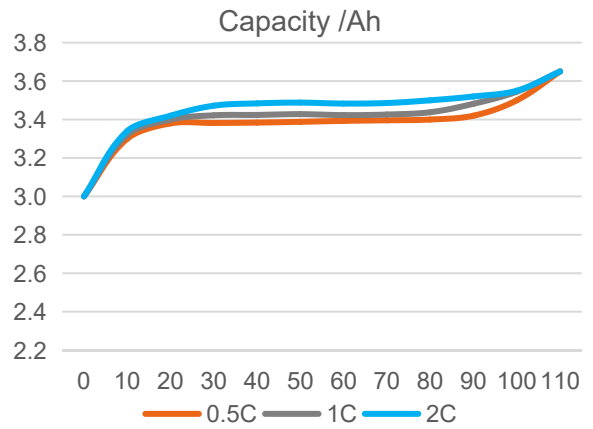
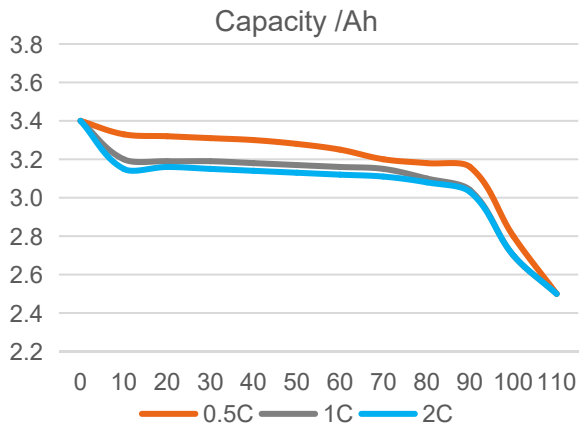

Charge/Discharge Capacity At Different Rates for Battery Pack [Room Temperatue]

0.5C Charge Voltage & Current & Capacity Curve

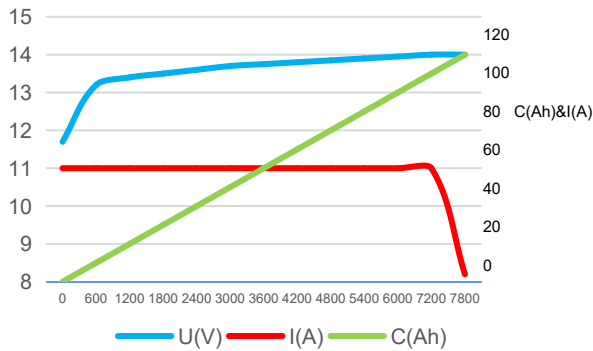

1.0C Discharge Voltage & Current & Capacity Curve

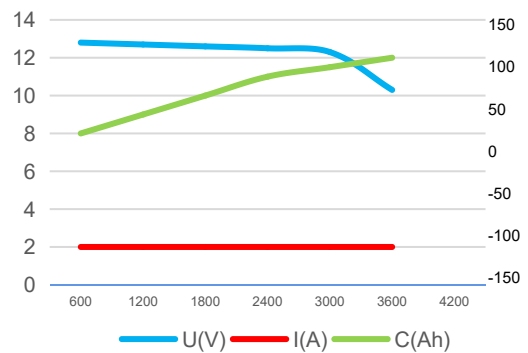

PRODUCT DISPLAY

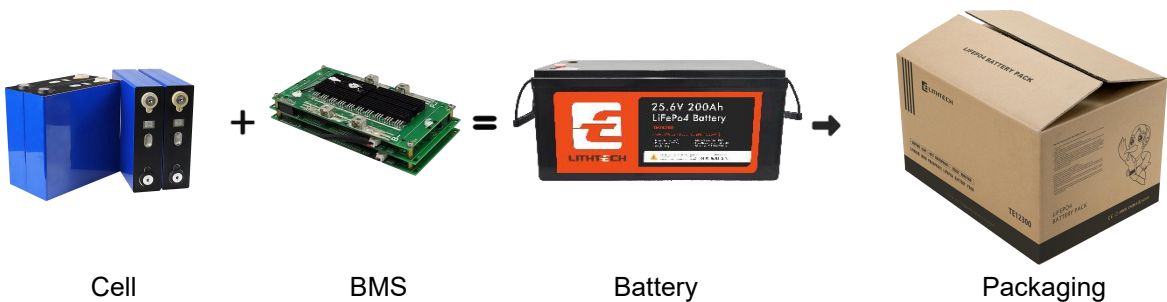



Strive to be the preferred partner
for the Global New Energy Industry

Shenzhen Lithtech Energy Co.,LTD

Web: www.ltc-energy.com

Email: info@lith-tec.com

Tel: +(00) 86 0755-23300421